



MAXIMUM HEIGHT  
OF 120MM



INTEGRATED INDICATOR  
WITH PROTECTION





ERGONOMIC HANDLEBAR  
EASY TO USE



## ARX PALLET TRUCKS WEIGHER

Quality design and finish, with a friendly use. Dust paint for maximum duration. Easy operation with multifunction indicator and LCD display.



FOLLOW US:  

More information on our code QR:  
<http://www.baxtran.com/en/pallet-truck/ax-lcd.html>



**FEATURES:**

- Weighing pallet truck.
- Structure in powdered painted steel.
- Wheels of cast steel and polyurethane external coating

**INDICATOR:**

- LCD display
- ABS housing. With steel impact protection part.
- IP54 protection.
- Units kg and lb.
- Bubble level.
- Rechargeable internal battery 6V 4,5Ah.
- Power supply with adaptor AC/DC 100-240Vac 50/60Hz.
- Operating temperature -10°C a 40°C.

**FUNCTIONS:**

- Accumulation
- Zero
- Tare
- Gross/ Net
- Piece counting function
- Checkweighing function
- Hold function
- Weight for percentage

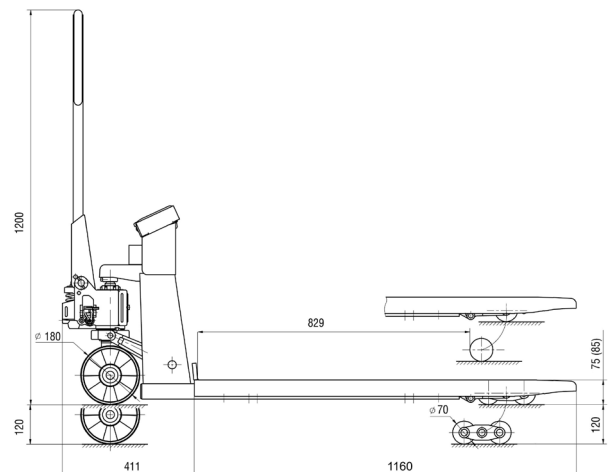
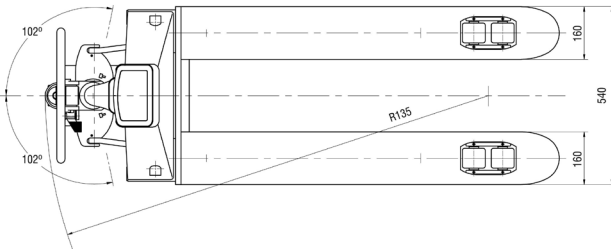

Code#	Capacity (kg)	Readout (g)	Packing dimensions (mm)	Packing weight (kg)
261026	2000	500	1220x1400x1000	88